

PART NO. 67667

Instruction Sheet

SUBARU REAR TOE CAM

Before beginning alignment check for loose or worn parts, proper tire pressures, and odd tire wear patterns. Replace any loose or worn parts.

Plan Ahead - Read All Instructions BEFORE installing part.

1. Remove factory toe cam assembly.
2. Assemble SPC toe cam by placing one cam over bolt.
3. Install Cam/Bolt assembly in place of OE cam bolt
4. Install cam and nut on opposite side of SPC Cam/Bolt assembly.
5. Hand tighten nut to take up slack, but still allow assembly to be rotated.
6. Adjust toe by turning bolt. Once desired setting is achieved, tighten nut to 75 ft-lb (102 Nm).

NOTE: Cam will use full throw of slot and will not be able to be turned 360°. If extended change is desired, you may be able to elongate hole by 2mm (use SPC #85127 Rotary File or equivalent) to take advantage of cam's offset (**Figure 1**).

7. Recheck alignment and road test vehicle.

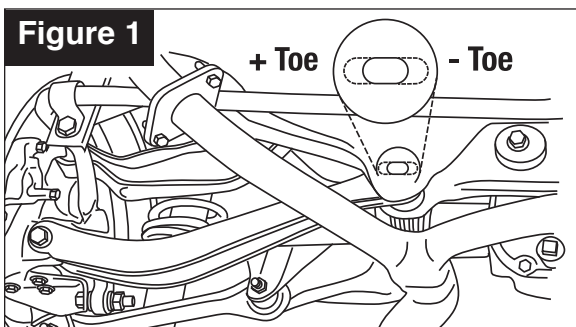

This part should only be installed by personnel who have the necessary skill, training and tools to do the job correctly and safely. Incorrect installation can result in personal injury, vehicle damage and / or loss of vehicle control.



**Specialty
Products
Company®**

P.O. Box 923 • Longmont, CO 80502 • (303) 772-2103

www.specprod.com • www.spcperformance.com

Email: info@specprod.com

Printed in U.S.A.

Toll Free Technical Hot Line: 1-800-525-6505

©2015 Niwot Corp. dba Specialty Products Co. • Form No. 67667WEB • Rev. 4/15